

Digital Processor Monitor

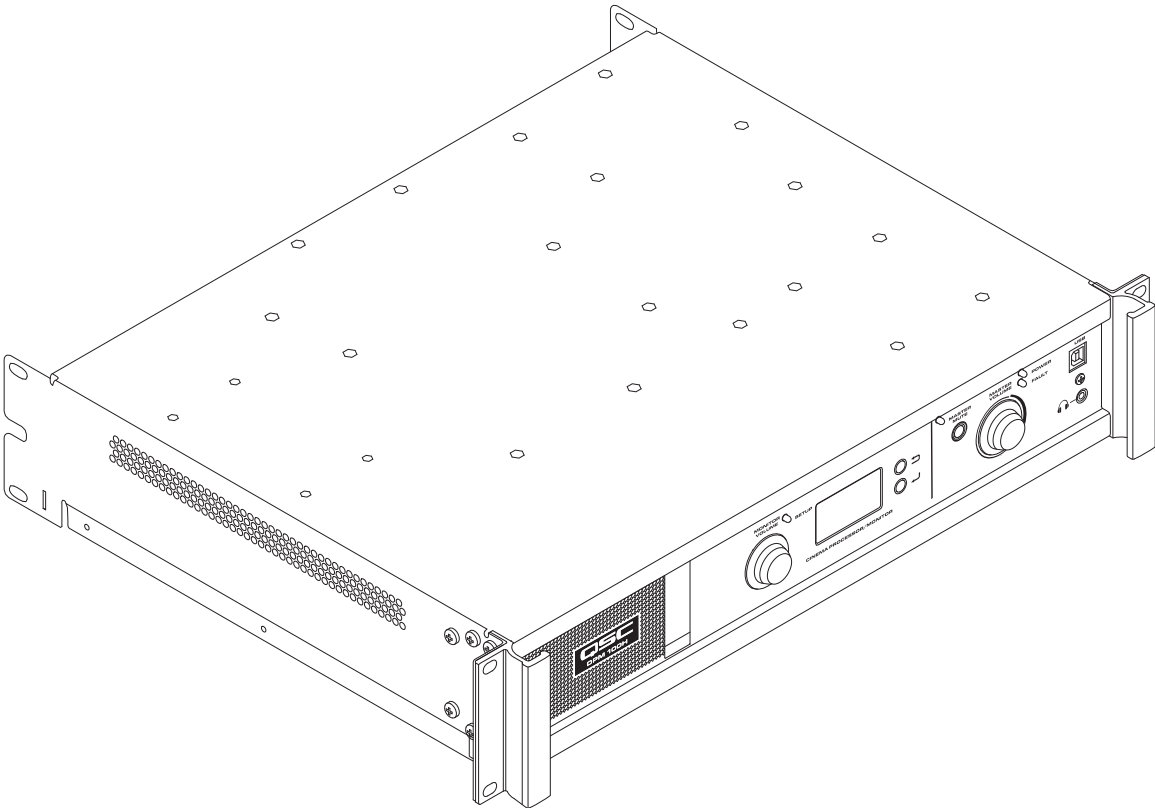

User Manual

DPM 100 | DPM 100H | DPM 300 | DPM 300H



TD-000515-01-D



Introduction

QSC's DPM is a powerful solution for today's D-Cinema audio systems. From server to speakers, the DPM offers a complete set of tools to facilitate all the signal processing, audio distribution, monitoring and automation control services required in a modern D-Cinema sound system.

The DPM builds on the legacy of QSC's DCM and DCP products to provide all signal processing and monitoring functions for Digital Cinema in a single integrated system. Designed to be used with QSC's Digital Cinema Amplifiers (DCA) and featuring advanced Intrinsic Correction™ settings for QSC's Digital Cinema Speakers (DCS), the DPM optimizes loudspeaker performance while simplifying cinema sound system wiring and configuration. The DPM 100 and DPM 100H are configurable for passive and bi-amp operation. The DPM 300 and 300H are also configurable for tri-amp and quad-amp operation. Though optimized to receive audio content directly from a D-Cinema server, the DPM is also compatible with all analog cinema processor formats and features an 8 channel analog input for integration with 35 mm audio systems.

The DPM is more than an audio processor. Whether designing a system for a single auditorium or designing a large multiplex, the DPM offers the flexibility in configuration, networking, audio distribution and advanced management services to get the job done.

Features

- Digital inputs accept AES-3 audio from a D-Cinema server or other digital audio source
- Analog inputs accept audio from film processors or other 8 channel analog audio sources
- Additional analog inputs accommodate non-sync and Mic/Line sources
- Additional digital inputs include HDMI® (DPM 100H and DPM 300H only) and SPDIF
- The DPM 100H and DPM 300H include Dolby Audio™ (featuring Dolby Digital Plus™) and DTS-HD® decoding.
- QSC Intrinsic Correction settings for optimal performance of QSC cinema speakers
- Master volume and full cinema processor EQ on all channels
- Booth monitor with front panel control for easy operation
- Passive or 2-way crossovers for three screen channels (all models)
- 3-way or 4-way crossovers for three screen channels (DPM 300 and 300H only)
- Compatible with all existing QSC DCA amplifiers
- Bypass mode – routes audio around failed components to ensure that the show will go on.
- Control and monitoring via Ethernet including full SNMP support
- Continued development of software and firmware will add new capabilities via easy updates



Package Contents

1. DPM 100, DPM 100H, DPM 300 or DPM 300H
2. User Guide TD-000515
3. IEC power cord
4. Euro style connector plug kit
5. Limited Warranty TD-000453-01

Rack Mounting

The DPM is designed to be mounted in a standard 19" (480 mm) equipment rack and requires 2 vertical rack spaces. Mount the DPM using four screws and washers. Tighten securely. The DPM comes with rear rack support ears. Make sure that the rear mounting points are securely fastened to rear rack rails or rack side walls.

Warranty

For a copy of the QSC Limited Warranty, visit the QSC website at www.qsc.com

Para una copia de la Garantía Limitada de QSC, visite el sitio web de QSC, en www.qsc.com

Pour obtenir une copie de la garantie limitée de QSC, visitez le site de QSC à www.qsc.com

Eine Kopie der beschränkten QSC-Garantie finden Sie auf der QSC Webseite unter www.qsc.com.

如果您想要QSC有限保修的複印本，請造訪QSC音頻產品的網站www.qsc.com

Для получения копии ограниченной гарантии QSC посетите веб-сайт QSC Audio Products, расположенный по адресу www.qsc.com.

للحصول على نسخة من الضمان المحدود الخاص بـQSC، قم بزيارة الموقع الإلكتروني لشركة QSC للمنتجات الصوتية على www.qsc.com

Controls and Connectors

Front Panel

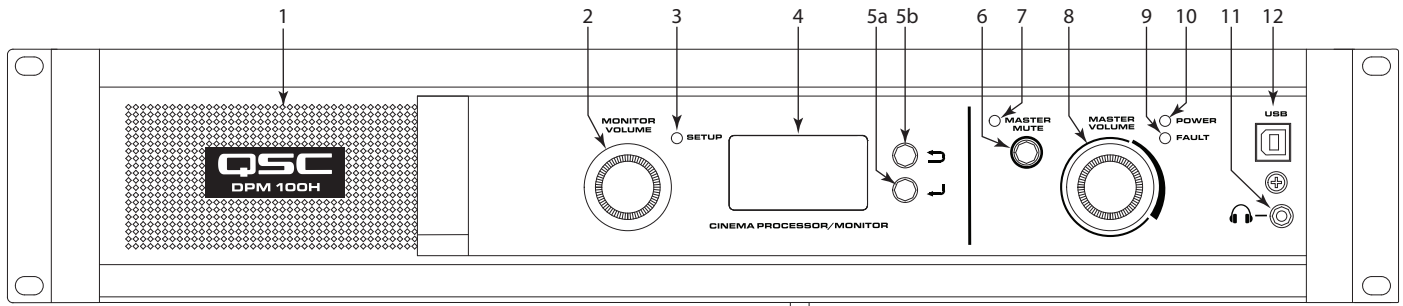

– Figure 1 –

1. Full-range monitor speaker
2. **MONITOR VOLUME** – Function depends on operating mode
 - a. Monitor mode – controls level to DPM front panel loudspeaker
 - b. Setup mode – provides parameter adjustment
3. **SETUP** mode indicator LED – illuminates yellow when Monitor Volume knob is in setup mode
4. 128 x 64 bit LCD monochrome display
5. Navigation
 - a. ➡ – press to navigate to a higher level menu
 - b. ⬅ – press to navigate to a lower level menu or edit a parameter
6. **MASTER MUTE** button – Mutes all outputs when engaged
7. **MASTER MUTE** LED – illuminates red when Mute is engaged
8. **MASTER VOLUME** knob – global level control for all audio outputs
9. **FAULT** LED – illuminates yellow when load faults or system errors are detected
10. **POWER** LED – illuminates green when AC power is applied
11. 🎧 – Headphone jack (3.5 mm TRS) for attaching external powered monitor speaker or headphones (automatically mutes speaker)
12. **USB** Type B port for DPM configuration and management.

Rear Panel Features

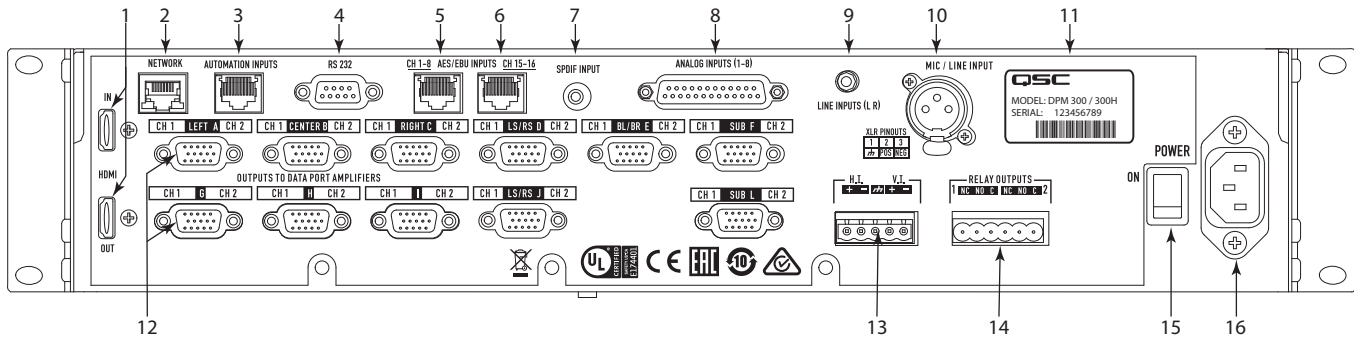

– Figure 2 –

- HDMI IN / OUT** (DPM 100H and DPM 300H only) – Extracts audio from incoming HDMI stream and passes stream directly to output HDMI port. Includes Dolby Digital Plus™, and DTS-HD® decoder.
- NETWORK** (RJ45) – 10/100 Mbps Ethernet port for DPM Manager, 3rd party control, or SNMP management and remote access.
- AUTOMATION INPUTS** (RJ45) – contact closures (control presets, mute etc.)
- RS 232** – Serial communications port for 3rd party control/automation
- CH 1-8 AES/EBU INPUTS** (RJ45) – AES3 pairs 1 through 4 (digital audio channels 1 through 8)
- CH 15-16 AES/EBU INPUTS** (RJ45) – AES3 pair 8 (digital audio channels 15 and 16, normally HI and VI)
- SPDIF INPUT** – SPDIF multi-channel digital input for non-sync/alternative content. Includes Dolby Digital Plus™ (DPM 100H and DPM 300H only) or Surround LtRt Matrix decoding.
- ANALOG INPUTS** (DB-25) – connect to D-Cinema server or film processor with analog outputs
- LINE INPUTS (L R)** (3.5 mm TRS) – Stereo analog line-level inputs
- MIC / LINE INPUT** (XLR) – Mono analog input accepts microphone or line-level signals (with phantom power)
- Serial Number and Model
- OUTPUTS TO DataPort™ AMPLIFIERS** (HD-15) connectors – For QSC DataPort amplifiers. There are 9 DataPorts on DPM 100/100H; 11 DataPorts on DPM 300/300H.) Use only QSC-supplied DataPort cables.
- H.I. / V.I.** – Hearing impaired and visually impaired special mix outputs
- RELAY OUTPUTS** – mechanically de-coupled control outputs (curtain, lighting control, and so on.)
- POWER ON / OFF** switch
- IEC connector – AC mains power connector

DPM Manager Software

DPM Manager is used to configure and manage your DPM and to configure the network settings if required.

Your computer must meet the following minimum requirements:

- Computer with Windows® 7, 8, or 10 OS (32 or 64 bit) or MAC OS 10.9.5 or higher
- 4 GB of RAM or greater
- Display resolution of at least 1024 x 768

Setup Overview

Initial configuration of the DPM is performed through QSC's DPM Manager software, which must be installed on a Windows® or MAC PC or laptop computer. Once the software is installed on the computer, the computer can then be connected to the DPM using a USB or Ethernet connection.

A system designer would typically begin high-level configuration by defining the basic system topology and distribution of audio within the DPM Manager application. This involves selecting the audio sources for the DPM program inputs, auditorium sound format, amplification, and speaker design. Presets can be created to accommodate multiple audio sources or distribution topologies (i.e., to support different configurations for the main theatre presentation and for alternative content/non-sync audio) and/or to support multiple auditorium mixes or multi-use applications.

Once the high-level configuration is complete, the rest of system can be connected to the DPM and/or powered up and completion of the DSP configuration, assignment of levels, and other system tuning can commence.



NOTE: Recalling system presets and adjusting system parameters such as output and monitor levels, monitor tap points, and so on, can be made through the front panel user interface.

The Setup Overview on the following pages is a general application guide showing the installation steps required for a basic system. Refer to the Help Files in DPM Manager for detailed setup and configuration instructions and for system examples. The QSC Cinema Products web pages are also a good source of information for application notes and system design assistance.

The following assumes that the DPM has been unpacked and mounted.

1. Install Software

Download the DPM Manager installation file from QSC.com. Follow the instructions to install.

2. Configure DPM

After DPM Manager is installed, connect a USB cable between the DPM and the computer. Turn the DPM on, launch DPM Manager and follow the prompts on screen. Refer to the Help Files for instructions on how to configure the basic operating parameters of the DPM (source inputs, format, presets, etc).

3. Attach Amplifiers

Connect DataPort outputs on the DPM rear panel to DataPort inputs on QSC's DCA or PL3 Series amplifiers using QSC approved DataPort cables.

4. Connect Audio

Connect cinema audio sources to the appropriate DPM rear panel input connectors. Main sources can come from digital content servers or analog film processors. Additional analog and digital inputs are provided for alternative content sources, live feeds, DVD players, mic/paging sources etc. Connect the Hearing Impaired and Visually Impaired special mix outputs to appropriate external devices as needed.

5. Connect Automation

Connect appropriate external control devices to the DPM's automation Inputs. Connect the Relay Outputs to any external devices to be controlled.

6. Tune System

Once the basic DPM operating configuration is defined and all of the connections are in place, it's time to power up the rest of the rack, complete the DSP setup, tune the system and run through final check.

Refer to additional information in this Hardware User Manual and in the software Help Files for further setup and configuration details to complete this step.

Configuration and Networking

The DPM offers a variety of options for configuring and managing the product and an entire cinema sound system locally or remotely. Local DPM configuration and system management are provided through directly applied connections to the DPM via universal serial bus (USB), the DPM front panel LCD and buttons or through a local Ethernet link. Remote and system-wide management are possible through more sophisticated network implementations and/or via wide area network (WAN) topologies, Internet access or 3rd party subscription services that make use of the DPM third-party API or SNMP.

Basic configuration of the DPM product is performed through the USB interface on the product front panel or via the Ethernet connection on the rear panel. The system designer connects to the DPM's USB port with a Windows or MAC laptop or PC running the DPM Manager software application. DPM Manager offers all the setup tools and system management objects to configure the auditorium audio format, selection of audio source material, configure the DSP signal path, apply crossovers, EQ etc., define the routing of audio to the amplifiers, define the system speakers and speaker processing etc. Once the basic configuration is complete, the system designer can define custom up to 16 custom Presets that can be recalled for different auditorium setups. For example, a Preset can be created for the primary presentation content. Another Preset can be created for non-sync or alternative content. And yet another Preset can be created for live application use such as seminars or corporate events. Once these Presets are created they become accessible via the DPM front panel user interface.

In addition to basic configuration, DPM Manager can be used to monitor health, status, and performance of the system via the product's USB or Ethernet interface.

USB Connection to DPM

Figure 1 item 12 illustrates the product's front-panel USB Type B port. Connect the USB cable to a laptop running QSC's DPM Manager to configure the DPM.

Local Ethernet connection to DPM

Figure 2 item 2 is used to connect the DPM to a network switch to allow setup, control and monitoring over Ethernet.

Configuring the DPM

DPM Manager is used to configure the DPM product. This includes configuring the device properties, the DSP objects, audio and control I/O and Presets. The network communications properties must be configured using DPM Manager over USB so that all networking properties are in place before the DPM is added to a local area network (if your deployment requires networking).

Once the DPM product is configured, DPM Manager can then be used to manage one or more DPM products over a local area network. Alternately, an SNMP-based management system may be used to monitor and control the DPM.

Refer to the information in the DPM Manager Help for additional information on product configuration, management and network connectivity.

Connections

AC Power Cord

Insert the molded receptacle of the AC power cord into the AC power inlet on the back of the DPM product. Plug the AC line connector into an AC outlet. The power supply on the DPM product will accept from 100 to 240V, 50 to 60 Hz.

Network

Connect one end of a data communications cable terminated with an RJ45 plug into the Ethernet receptacle on the rear panel of the DPM product. Ensure that the lock tab on the cable engages with the RJ45 receptacle on the DPM rear panel connector. Note: data communications cabling must be rated CAT-3 or better for 10 Mbps network connections or rated CAT-5 or better for 100 Mbps network connections.

Hearing and Visually Impaired Outputs (H.I./V.I.)

The Hearing Impaired and Visually Impaired special mix outputs are balanced outputs that are combined into a single 5-terminal Euro style (a.k.a. Phoenix) receptacle. This combo receptacle includes a common ground for both the H.I. and V.I. outputs. Terminate the mating 5-terminal Euro plug and insert it into the DPM rear panel receptacle as shown in Figure 3. The DPM rear panel label provides a pin-out of the receptacle signals. Note: a standard 3-terminal plug may be used if only one output is required.

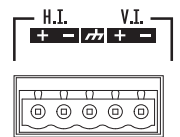

– Figure 3 –

Automation Inputs

The automation inputs use an RJ45 connector. The Automation Inputs can be connected to relay contacts or a switch.

Relay Outputs

Two relay outputs are provided via two 3-terminal Euro style (a.k.a. Phoenix) receptacles. Relay contacts are floating and rated for 30 VDC at 1A. Each output includes one common terminal, one normally open contact (N.O.) and one normally closed (N.C.) contact. These terminals are labeled C, NO and NC, respectively on the DPM rear panel. When the relay is not energized, the C terminal is connected to the NC contact and the NO contact is not connected. When the relay is energized, the C terminal is connected to the NO contact and the NC contact is not connected.

Automation In (RJ45)	
Pin #	Description
1	GPI 1
2	GPI 2
3	GPI 3
4	GPI 5
5	GPI 6
6	GPI 4
7	UNUSED
8	GND

DataPorts

QSC DataPorts on the DPM rear panel are intended to interface to QSC amplifiers with v1 DataPorts. These are the all-capable DataPorts, which are included on DCA and PL3 series amplifiers. All DataPorts use the HD15 connector format and connect to QSC amplifiers via data communications cables having male HD15 connectors on both ends. These are commonly referred to as VGA cables. Note: though many off-the-shelf VGA cables may work with satisfactory results, the QSC DataPort specification requires that all conductors be present and that all audio I/O conductors be shielded. Therefore, only QSC supplied DataPort cables should be used. A variety of lengths are available through QSC's Technical Services Group. To connect a DataPort cable between a DPM DataPort and an amplifier DataPort, attach the cable's male connectors to the HD15 ports and finger tighten the thumb screws on the connectors.

Ancillary Interfaces

A single Mic/Line Input is accessible on the DPM rear panel. This input can be used for mono non-sync sources or for connecting a microphone for local paging or announcements into the auditorium or to support various corporate or live events requiring a microphone. Alternately a microphone can be permanently connected to provide SPL metering of the theater. Phantom power may be enabled via DPM Manager configuration or via the DPM front panel interface. The Mic/Line Input uses a standard 3-conductor XLR receptacle.

L/R analog line input connectors and a multi-channel digital SPDIF input are accessible on the DPM rear panel. These connectors accommodate non-sync sources appropriate for alternative content, advertising, corporate or live event feeds.

HDMI In/Out connectors are provided to allow audio inputs from alternate content sources with HDMI outputs such as laptops or satellite receivers. The HDMI input signal is passed through to HDMI output for connection to downstream video devices.



NOTE: All ancillary interfaces use standard cables that are readily available through retailers specializing in computer equipment, musical equipment, pro audio or home electronics.

Main Analog Input Connector Pinout (DB25 Female)

Pin #	Description	Pin #	Description
1	Chassis ground	14	Left -
2	Left +	15	Chassis ground
3	Left extra -	16	Left extra +
4	Chassis ground	17	Center -
5	Center +	18	Chassis ground
6	Right extra -	19	Right extra +
7	Chassis ground	20	Right -
8	Right +	21	Chassis ground
9	Chassis ground	22	Chassis ground
10	Surround left -	23	Surround left +
11	Surround right -	24	Surround right +
12	Subwoofer -	25	Subwoofer +
13	Chassis ground	Shell	Chassis ground

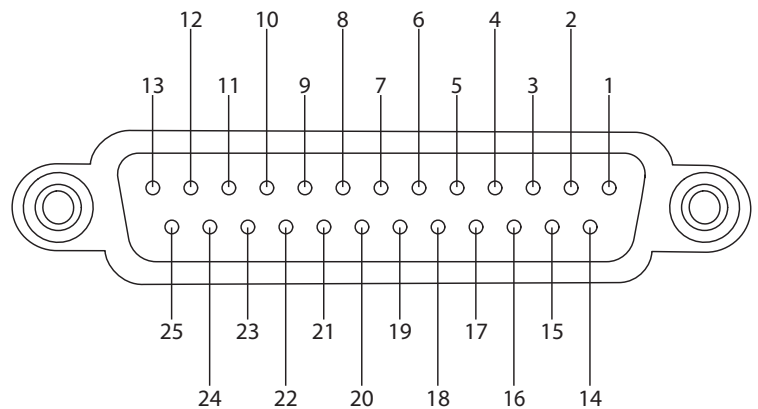

– Figure 4 –

Digital (AES3) Input Connector Pinout (RJ45)

AES/EBU INPUTS 1-8			AES/EBU INPUTS 15-16		
Pin #	Description	Channel	Pin #	Description	Channel
1	AES Pair 1: +	L, R	1	AES Pair 1: +	Unused
2	AES Pair 1: -		2	AES Pair 1: -	Unused
3	AES Pair 2: +	C, Sub	3	AES Pair 2: +	Unused
4	AES Pair 3: -		4	AES Pair 3: -	Unused
5	AES Pair 3: +	LS, RS	5	AES Pair 3: +	Unused
6	AES Pair 2: -		6	AES Pair 2: -	Unused
7	AES Pair 4: +	BL, BR	7	AES Pair 4: +	HI, VI
8	AES Pair 4: -		8	AES Pair 4: -	

Specifications

Parameter	Specification
Front Panel Controls and Indicators	
Monitor Volume/parameter adjust	Rotary encoder
Setup mode indicator	Yellow LED
LCD	128 x 64 bit Monochrome LCD
Master Mute indicator	Red LED
Master Mute	Push button
Master Volume	Rotary encoder
Power on indicator	Green LED
Fault detect indicator	Yellow LED
USB Type B port	Config and management interface
Monitor output	3.5 mm TRS
Rear Panel Connectors	
Network RJ45	10/100 Mbps network management
Automation Inputs	RJ45 – 6 contact closure inputs
RS232	DB-9 Serial Interface
Channels 1-8 AES3/EBU Inputs	RJ45
Channels 15-16 AES3/EBU Inputs	RJ45
S/PDIF Input	RCA – Stereo digital audio interface and Lt/Rt Matrix
Analog Inputs (1-8)	DB-25
Line Inputs	3.5 mm TRS – Stereo Left and Right and Lt/Rt Matrix
Mic/Line input	XLR – Mic +15V phantom power or line level
HDMI input/output	Type A female connectors
DataPort connectors	HD-15 (9 or 11) – QSC amplifier interface
H.I./V.I. output	5-pin Euro-style (x1) – common GND
Relay outputs	3-pin Euro-style (x2) – max 30 VDC
Power switch	Rocker switch
Monitor Speaker	
Speaker	2"x 3.5" full-range
Impedance	4 Ω
Amplifier output power	10 watts Class D
Frequency response	20 Hz – 20 kHz (± 2 dB)
Analog Inputs/Outputs	
General Audio Performance Requirements	
A/D conversion	24-bit delta-sigma, 48 kHz
Frequency response:	20 Hz to 20 kHz (+/- .5dB)
Main Analog Input (DB25F - 8 channel)	
Active balanced input	
Input impedance:	20k Ohm
Max analog input level:	+14.2 dBu (4.0 Vrms)
Dynamic range (unweighted):	> 106 dB
Dynamic range (A-weighted):	> 108 dB
THD+N at 2 dB below clip:	< 0.003%

Parameter	Specification
Mic/Line Input (XLR)	
Active balanced input	
Input impedance:	2.2k Ohms
Max analog input level:	26 dBu
Dynamic range (unweighted):	> 106 dB
Dynamic range (A-weighted):	> 108 dB
THD+N at 10 dB below clip (26dBu sens):	< 0.02%
THD+N at 10 dB below clip (21 dBu sens):	< 0.003%
Input gain	0 to 60dB in 1 dB steps
CMRR typical 20 Hz – 20 kHz:	> 50dB
EIN:	< -122 dB
Phantom power voltage:	15V
Stereo Line Inputs (3.5mm minijack)	
Unbalanced input	
Input impedance (4dBu sens):	> 10k Ohms
Max analog input level (4dBu sens):	14 dBu (4.2 Vrms)
Input impedance (-10dBV sens):	2.7k Ohms
Max analog input level (-10dBV sens):	0 dBV (1 Vrms)
Headroom (all sens):	> 10dB
Dynamic range (unweighted):	> 106 dB
Dynamic range (A-weighted):	> 108 dB
THD+N at 2 dB below clip:	< 0.003%
DataPort Outputs (HD15)	
Max output level:	14 dBu
Dynamic range (unweighted):	> 109 dB
THD+N at 2dB below clip:	<.002 %
HI/VI Outputs (5-pin Euro-style with common GND)	
Balanced output	
Max output level:	18 dBu (adjustable)
Dynamic range (unweighted):	> 109 dB
THD+N at 2dB below clip:	<.002 %
Monitor Headphone Output (Front Panel 3.5mm minijack)	
Unbalanced output	
Max output level:	21 dBu
Dynamic range (unweighted):	> 109 dB
THD+N at 2dB below clip:	<.025 %

Parameter	Specification
Digital Inputs/Outputs	
AES/EBU Digital Inputs (RJ45)	
Balanced input	
Input sample rate	48 kHz or 96 kHz
S/PDIF Digital Inputs (Mono RCA)	
Unbalanced input	
Stereo PCM or Dolby Digital Plus™ (DPM100H only)	
HDMI Input/Output (DPM 100H and DPM 300H only)	
HDMI	Type A Connector
PCM, DTS-HD®, or Dolby Digital Plus™	
Other	
Line voltage requirements	100 VAC – 240 VAC, 50/60 Hz
Dimensions (H/W/D):	3.5"(2 RU) x 19" x 15"
Accessories included	6 ft UL/CSA line cord, Connector Kit

Parameter	Specification
Relay outputs (2)	
3-pin Euro-style	
Normally open, normally closed and common	
Max 30 VDC @ 1A	
Automation inputs (RJ45 - 6 GPI)	
Max input voltage	5V (3.3V typical)
TTL compatible dry contact closure	
Network / SNMP	
Protocol	Standard TCP/IP implementation over Ethernet or Fast Ethernet. 3rd party interface may use UDP/ IP or TCP/IP.
Data rate	10/100 Mbps
Connection requirements	Cat-5 UTP cable or better (100m maximum length), direct connection to wired network switch ports only, dedicated LAN or VLAN



Mailing Address:

QSC, LLC
1675 MacArthur Boulevard
Costa Mesa, CA 92626-1468 USA

Telephone Numbers:

Main Number: (714) 754-6175
Sales & Marketing: (714) 957-7100 or toll free (USA only) (800) 854-4079
Customer Service: (714) 957-7150 or toll free (USA only) (800) 772-2834

Facsimile Numbers:

Sales & Marketing FAX: (714) 754-6174
Customer Service FAX: (714) 754-6173

World Wide Web:

www.qsc.com

E-mail:

info@qsc.com
service@qsc.com
CinemaTechSupport@qsc.com

©2018 QSC, LLC. All rights reserved. QSC, the QSC logo are registered trademarks of QSC, LLC in the U.S. Patent and Trademark office and other countries. Intrinsic Correction is a trademark of QSC, LLC. Windows is a trademark of Microsoft Corp.

For DTS patents, see <http://patents.dts.com>. Manufactured under license from DTS, Inc. DTS, the Symbol, DTS in combination with the Symbol, the DTS-HD logo, and DTS-HD Master Audio are registered trademarks or trademarks of DTS, Inc. in the United States and/or other countries. © DTS, Inc. All Rights Reserved.

Manufactured under license from Dolby Laboratories. Dolby, Dolby Audio, Dolby Digital Plus, and the double-D symbol are trademarks of Dolby Laboratories. Confidential unpublished works. Copyright 1992-2015 Dolby Laboratories. All rights reserved.

All other trademarks are the property of their respective owners. Patents may apply or be pending.

<http://patents.qsc.com>.