

THIS DOCUMENT CONTAINS PROPRIETARY INFORMATION WHICH IS THE PROPERTY OF QSC AUDIO PRODUCTS. THAT MAY NOT BE DISCLOSED, REPRODUCED OR USED WITHOUT EXPRESS WRITTEN CONSENT FROM QSC AUDIO PRODUCTS.

REVISIONS			
REV	DESCRIPTION	BY	DATE
A	RELEASE FOR SALES AND MARKETING	SS	14-SEP-15

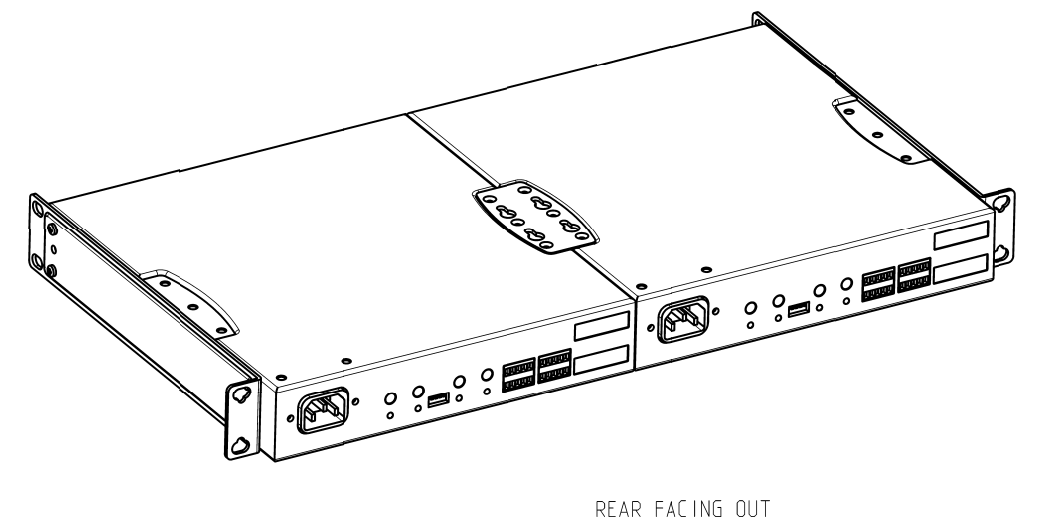
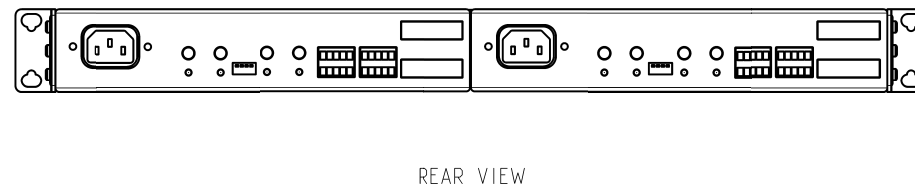
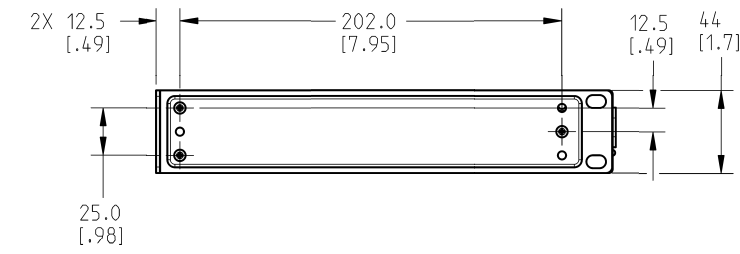
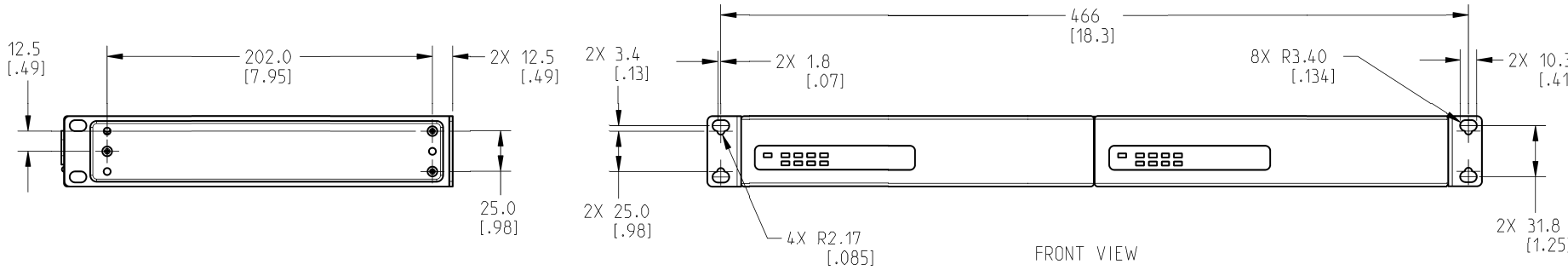
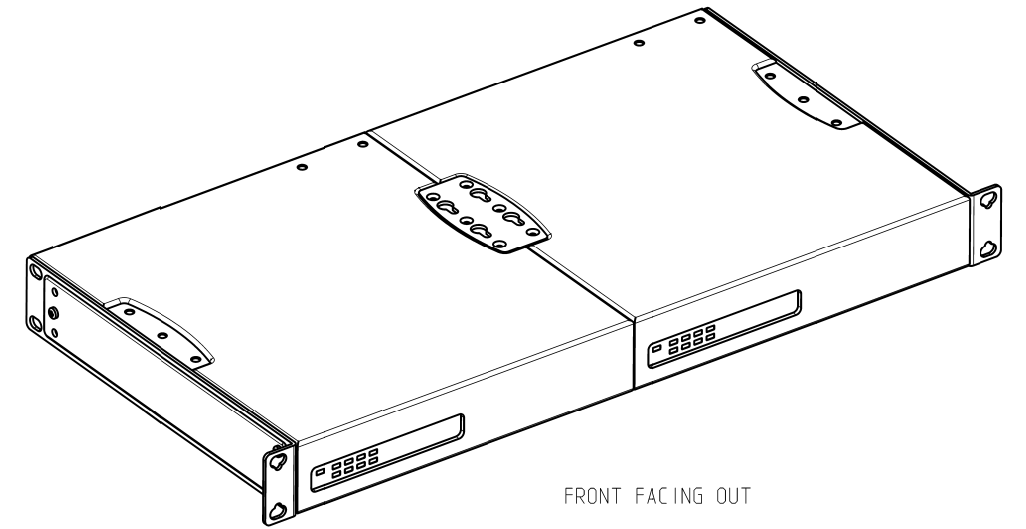
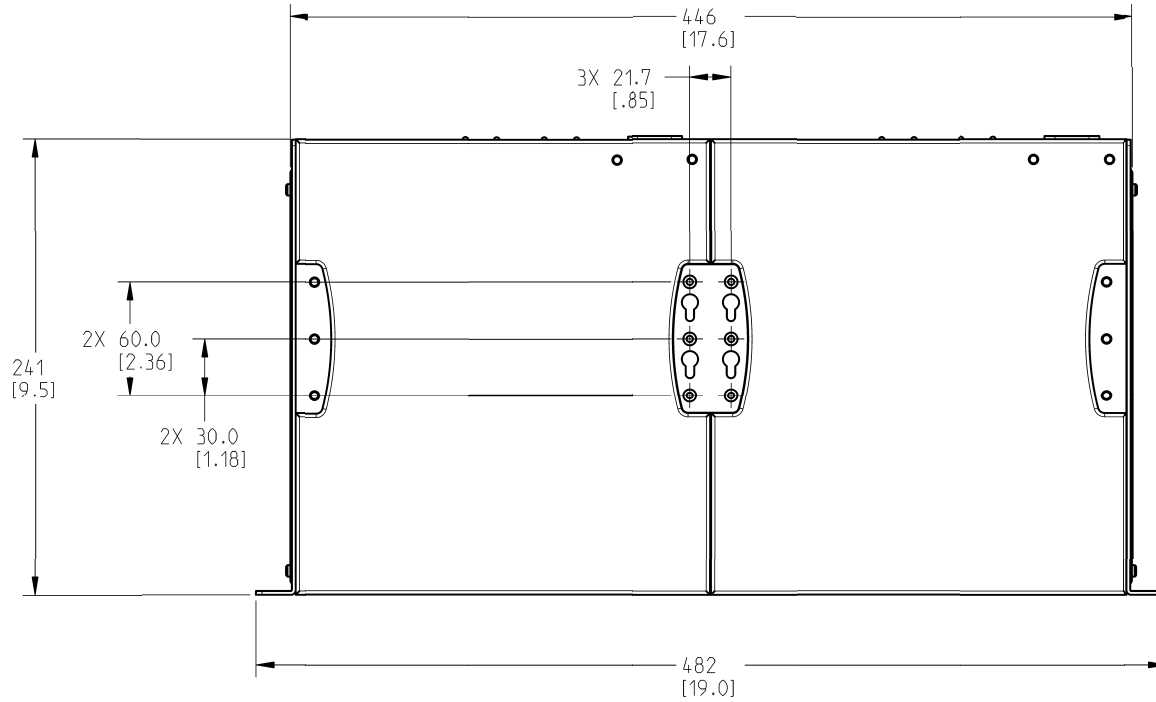

6. THE FRONT MOUNTING CONFIGURATION IS DIMENSIONED, THE REAR MOUNTING CONFIGURATION IS SIMILAR.
5. MEETS UL2043 WITH PLENUM KIT FG-000995-00.
4. MEETS ENERGYSTAR REQUIREMENTS.
3. CHASSIS DESIGNED TO MEET 1U RACK MOUNT SPECIFICATION IEC60297-3-100.
2. FEATURES SYMMETRICAL ABOUT CENTERLINE.
1. NET WEIGHT OF SPA4-60 APPROX. 1.4 KG (4.0 LBS). HARDWARE IS ADDITIONAL WEIGHT.

NOTES: UNLESS OTHERWISE SPECIFIED.

UNLESS OTHERWISE SPECIFIED DIMENSIONS IN MILLIMETERS (IN) TOLERANCES ARE: DECIMALS DECIMALS ANGLES .X±.01 .XX±.010 ± 1/2 DEBURR EDGES .25 (.010) R MAX	DESIGNER	ENGINEERING SERVICES	QSC QSC AUDIO PRODUCTS, LLC 1675 MACARTHUR BOULEVARD COSTA MESA, CA 92626
	ENGINEER	-	
	TECHNICAL DIRECTOR	-	SPA4-60, TANDEM MOUNT, 19-INCH
	MANUFACTURING ENGINEER	-	SIZE CAGE CODE DRAWING NO. REV D 00PW4 FG-004404-2D-B A
FINISH	DRAWING INFO: FG-004404-2D-B.A.2 MODEL INFO: FG-004404-3D-B2A.1		SCALE: 0.500 DO NOT SCALE DRAWING SHEET 1 OF 1